

LOGOSOL USER MANUAL

ORIGINAL USER MANUAL.



TWIN BLADE BOARD EDGER LOGOSOL C210



Read through the user manual carefully and make sure you understand its contents before you use the machine.



This user manual contains important safety instructions.



WARNING! Incorrect use can result in serious or fatal injuries to the operator or others.

Thank you for choosing a Logosol machine!

Logosol has a broad wood processing and woodworking product program. The product program includes machines and aids that allow you to handle the entire production process from felling to finished product.

We produce special moulders/planers that are specifically designed for sawmill owners. Examples include the PH 260 and PH360 which profile all four sides of a board in one operation. These machines allow you to further process and refine your sawed products after sawing and so increase the earnings achieved on your activities.

We have also a log moulder which is suitable for most smaller band sawmills, irrespective of manufacturer. We have blades for all types of bandsaws, chainsaws, bars, chains and many intelligent accessories for small scale wood processing.

Ring Logosol and we will send you information on our entire program. There are films on our website which show our products in action.

Our goal is that you are completely satisfied with your new board edger and that you, based on this, wish to continue working with Logosol, as a trusted partner, in the development of your activities.

Mattias Byström

Owner and product manager
LOGOSOL AB



LOGOSOL continuously develops its products.

For this reason, we must reserve the right to modify the configuration and design of our products.

Text: Mattias Byström

Document: Kantverk_Manual_se

Last revised: 14 September 2012

Manual, part no.: 0458-xxx-xxxx

Copyright 2012, LOGOSOL, Härnösand, Sweden

Table of contents

Safety rules	4
Safe distances	5
Summary	6
Tools needed	10
Description of machine	10
Lifting instructions	11
Transport	11
Siting	12
Control panel	13
In-feed and out-feed table	14
Sawdust handling	14
Settings	15
Edging boards	16
Electrical system	17
Wiring diagram	18
Maintenance	19
Feeder unit	19
Replacing circular sawblades	21
Technical data	22
EU declaration	23

•••••
 • **NOTE!** Check the board edger as soon as you •
 • receive it. Any transport damage is to be im- •
 • mediately reported to the transport company. •
 •••••

SAFETY RULES

KEY TO SYMBOLS



For your own safety, read through the user manual carefully and do not start the machine before you have understood everything. Do not let persons who have not read the manual, use the machine.



Risk of cut injuries. Wear protective gloves when handling circular saw blades. It is particularly important to wear gloves when opening or tightening blade locking screws (the tool can easily slip).



Use approved ear protectors. Hearing can be damaged by just short exposures to high frequency noise. Use approved protective eyewear. Splinters and wood pieces can be thrown out with great force during processing.



Warning for cutting tools. Never place your hands or tools above or below the edging table or in the sawdust ejector when in operation.



This symbol means 'WARNING!'. Pay particular attention where this symbol appears in the manual text.



A warning comes after this symbol. Pay particular attention where this symbol appears in the manual text.



The edger can cause serious body injuries where incorrectly operated. Make sure you are therefore fully concentrated on the operation of the unit and are very careful when you use the machine.

Never stand in the path of a board. This applies both to the in-feed and the out-feed side. The board or sawn-off pieces can be thrown out of the machine. Branches, splinters or pieces of metal can also be thrown out at great speed. Always stand beside the in-feed table.

Only one work piece at a time is to be fed through the machine.

Do not feed in workpieces which are too thin or too conical, as this can result in the feeder rollers losing their grip.

Before the machine is connected to the electricity supply:

- Check that the sawblades can rotate freely and that no tools or loose components have been left in the machine.
- Check that all inspection hatches are correctly fitted
- Check that the circular sawblades and the stop are correctly fitted and that all bolted joints are fully tightened.

Note that all bolts must be checked tightened after transport.

'Shut off the power' means that the cable with the CCE contact, which supplies the machine with power, is disconnected from the machine and is placed in such a way that no unauthorised persons can re-connect it. The cable is to also be placed so that there is no risk that it can be treaded upon or tripped over.

Shut off the power by pulling out the contact and waiting until the sawblades has stopped:

- before you open any inspection hatches on the machine.
- before cleaning or carrying out other service work
- before the machine is moved.
- if the machine is to be left unattended.

If a sawdust duct is fitted to the machine, then the exhaust hose and chip extractor are to be connected and are to be securely fastened such as by using hose clips.

The machine should be fitted with an in-feed and out-feed table with a length on each side of minimum 1 m.

Never use the machine under poor visibility conditions. Always work under good lighting.

Keep the workplace clean and tidy. Do not place anything on the ground which you can later trip over.

Never place your hands or tools above or below the table when the machine is in operation.

Never place tools on the edging table.

Do not climb onto the machine.

Do not tread on the machine's electric cable. The cable is to be protected against unintentional damage.

Make sure that the machine is positioned in such a way that access to the emergency stop button is not blocked.

For greatest electrical safety, use a residual current device.

The machine is not to be modified and is not to be added to.

Only use original parts supplied by Logosol which are designed for the purpose. **After servicing, the machine should be in its original condition.** All inspection hatches and protection devices must be correctly fitted before the machine is brought into use.

The machine's warning markings are there for your own and other's safety. Damaged or illegible labels are to be replaced.

Operator requirements: The machine is to only be used by persons who have read and understood this user manual, are more than 15 years of age, are in no way mentally incapacitated and who have good vision.

Do not use the machine if you are under the influence of alcohol or other narcotics or medicines.

Do not wear loosely hanging clothes or anything else which can get caught up in the machine's moving parts. Fasten long hair up in a secure way.

Circular saw blade bluntness increases the risk of an accidents.

 Risk that the workpiece or parts of the workpiece are thrown out of the machine. Stand alongside the workpiece and not in front of or behind the workpiece.

 The minimum permitted workpiece length: 0.8 m.

 The workpiece's minimum thickness: 13 mm.

 The workpiece's maximum thickness: 30 mm.

 The workpiece is not to be warped or bowed such that the total height is greater than 33 mm.

 Make sure that you are familiar with all functions and settings options before you begin using the machine.

CHECK BEFORE START

Risk of personal injuries. Carry out the following checks before each start.

Check that no unauthorised persons are closer than the safe distance from the edger.

Check that no tools or other metal objects are on the in-feed table or on the machine.

Check your personal safety equipment and make sure that no hair or clothes are hanging loose.

SAFE DISTANCES

 Risk of personal injuries

 No-one other than the operator is to be closer than 2 metres from the sides of the machine or closer than 5 m from the in-feed or out-feed side i.e. in the path of the workpiece. The safety of stationary installations can be increased by a wall or other barrier being set-up which stops any materials thrown out of the machine.

The machine's extension table increases safety by preventing the operator from entering the risk area closest to the machine. Refer to the symbol key for the adjacent safe distance.

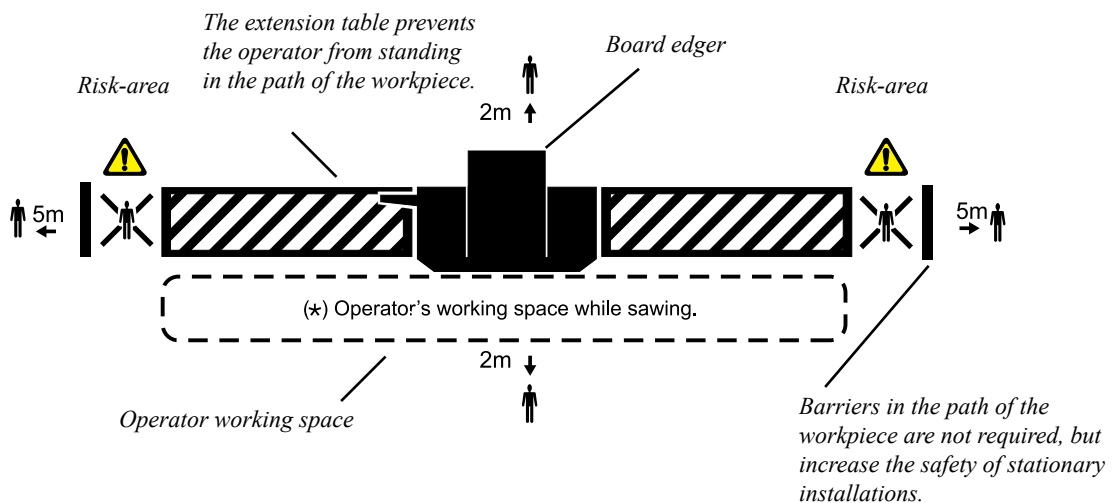

SUMMARY

-	5220-000-1000	Board edger, 400V	48	4900-001-0015	Roller (chain tensionor)
-	5220-000-2000	Board edger, 230V	49	5220-001-0278	Feeder roller, in
1	5220-001-0001	Rail	50	5220-001-0281	Chain 1/2" z=86
2	5220-001-0181	Carriage (4 pcs)	51	5220-001-0284	Chain lock 1/2"
3	5220-001-0007	Lifting eye	52	5220-001-0066	Control panel, board edger NO, 230V
4	5220-001-0010	Protective plate, right	53	5220-001-0064	Control panel, board edger, 400V
5	5220-001-0013	Protective plate, left	54	5220-001-0004	Sawdust plate
6	5220-001-0016	Hatch, front	55	8220-001-0034	Sawdust duct TF410
7	5220-001-0019	Riving knife, long	56	5220-001-0043	Rack, bottom
8	5220-001-0022	Hatch, rear	57	7202-001-0068	Limit switch
9	5220-001-0028	Riving knife mounting	58	8020-001-0230	Handle
10	5220-001-0031	Service hatch			
11	5220-001-0037	Rack, top			
12	5220-001-0040	Protective plate, front			
13	5220-001-0046	In-feed table			
14	5220-001-0049	Out-feed table			
15	5220-001-0052	Guide			
16	5220-001-0059	Eccentric locking lever			
17	5220-001-0061	Guide rail			
18	5220-001-0068	Washer, plastic			
19	5220-001-0075	Cable (limit switch - motor)			
20	5220-001-0151	Sawdust protector			
21	5220-001-0005	Sawdust plate, leaning			
22	5220-001-0154	Locking nut M35x1.5			
23	5220-001-0158	Circular sawblade			
24	5220-001-0160	Cylindrical pin (blade mounting)			
25	5220-001-0163	Inner blade mounting			
26	5220-001-0166	Outer blade mounting			
27	5220-001-0169	Motor mounting			
28	5220-001-0172	Riving knife, short			
29	5220-001-0175	Blade adjustment			
30	5220-001-0178	Motor, 2.2kW			
31	5220-001-0201	Gas spring			
32	5220-001-0204	Ball cup M6 Ø10			
33	5220-001-0207	Ball fitting M6 Ø10			
34	5220-001-0210	Hatch, pressure roller, out			
35	5220-001-0213	Holder, pressure roller			
36	5220-001-0216	Roller, pressure roller, out			
37	5220-001-0219	Pressure roller shaft			
38	5220-001-0222	Stop ring			
39	5220-001-0225	Hatch, pressure roller, in			
40	5220-001-0228	Roller, pressure roller, in			
41	5220-001-0251	Feeder roller, out			
42	5220-001-0254	Mounting, gear			
43	5220-001-0257	Chain drive z=12			
44	5220-001-0263	Gear assembly			
45	5220-001-0266	Wedge 36x5x5			
46	5220-001-0269	Wedge 14x5x5			
47	5220-001-0272	Bearing housing, feeder roller			

Refer to summary pictures on page 7, 8 and 9

LUBRICATION POINTS

- Bearing brackets for feeder unit
- Chain
- Rail
- Pressure rollers' bearing and moving parts.

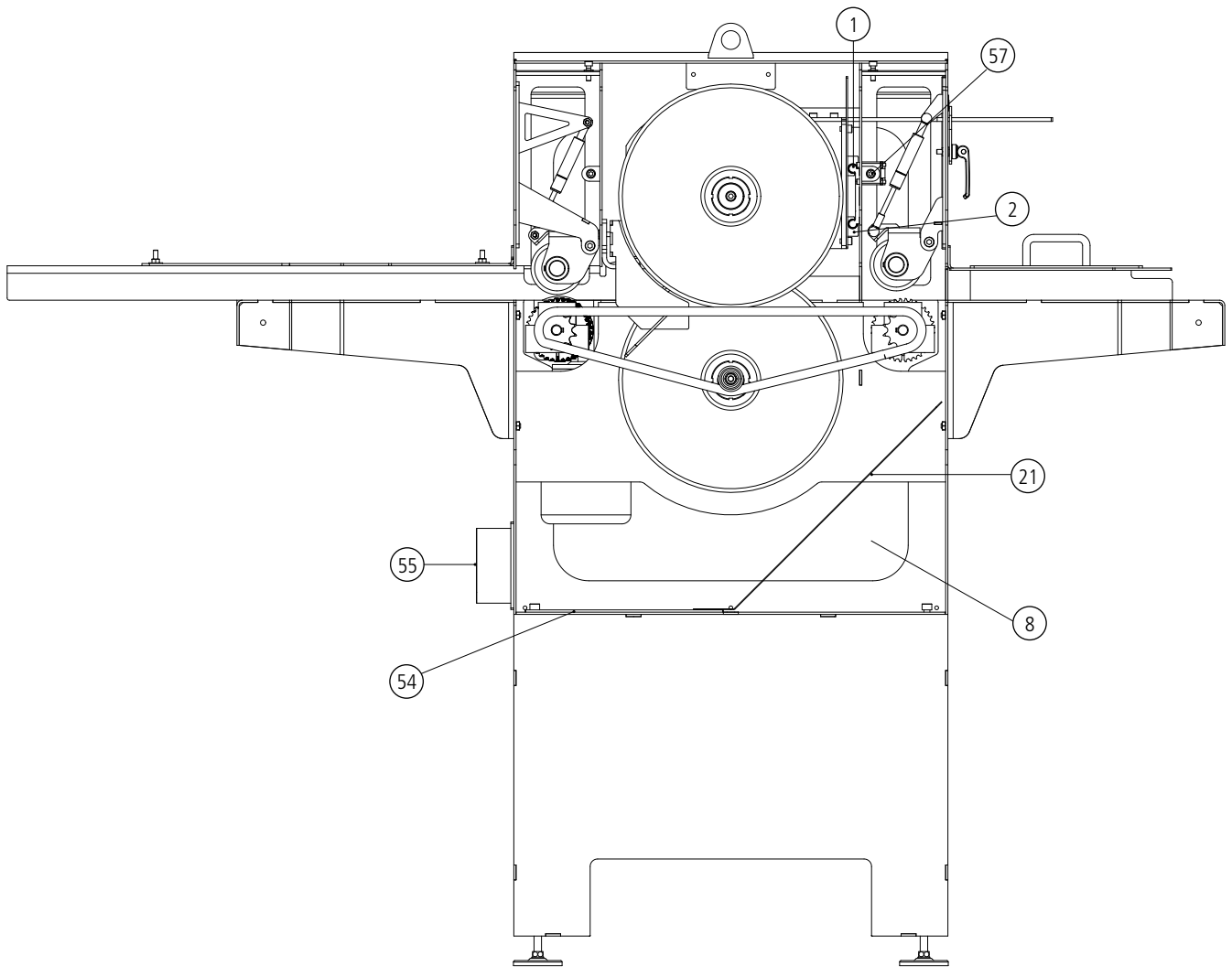

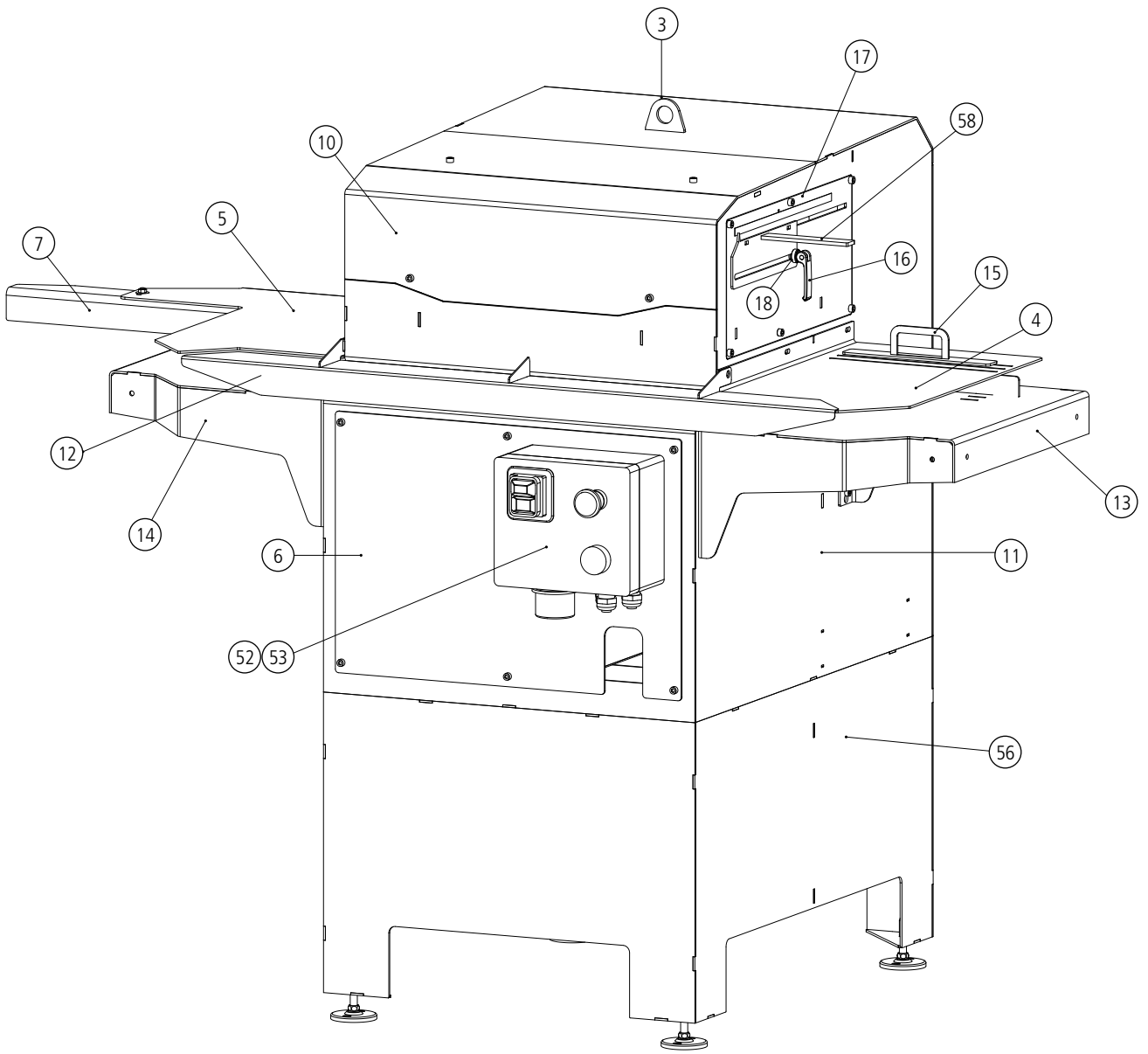

POWER SUPPLY

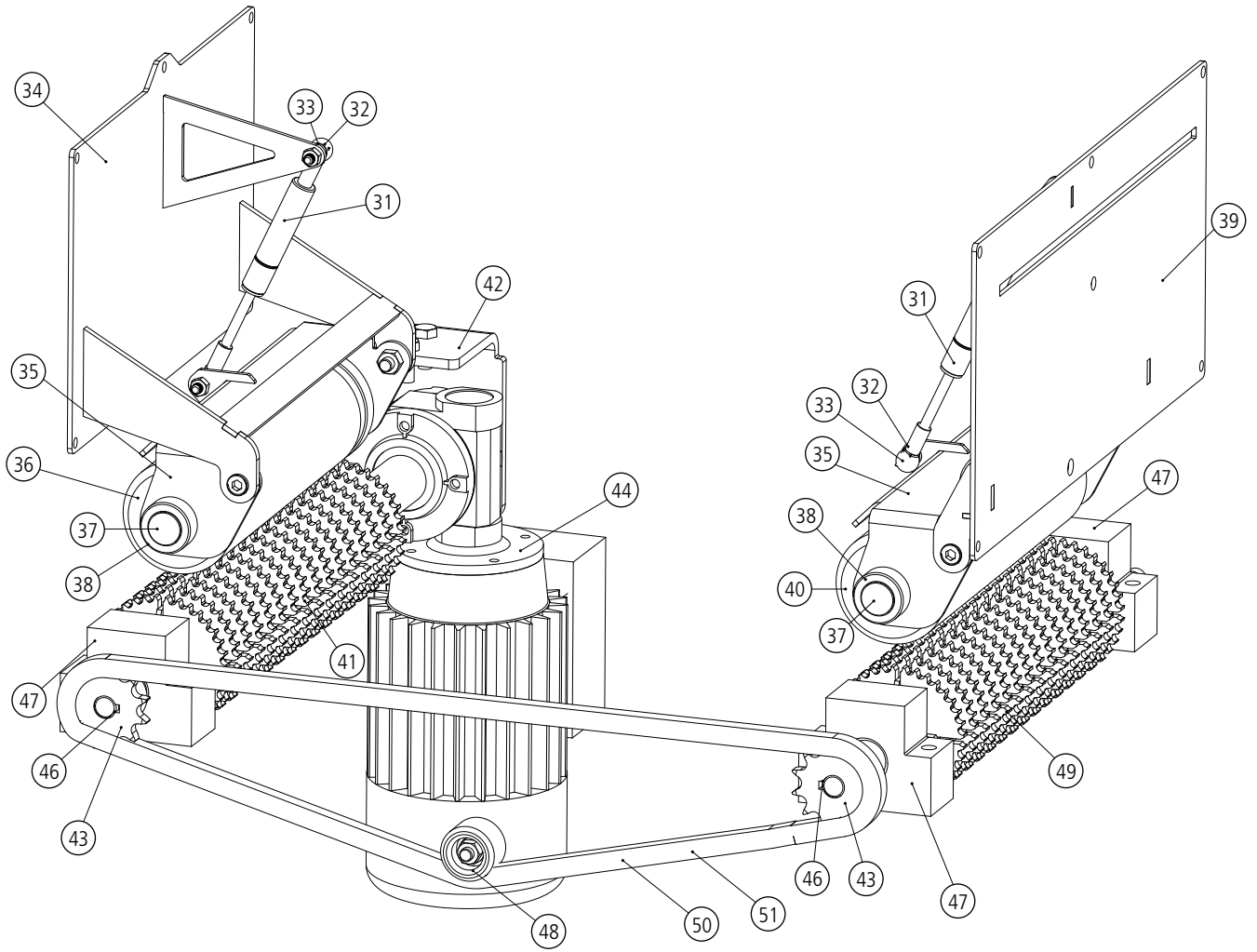

TOP MOTOR

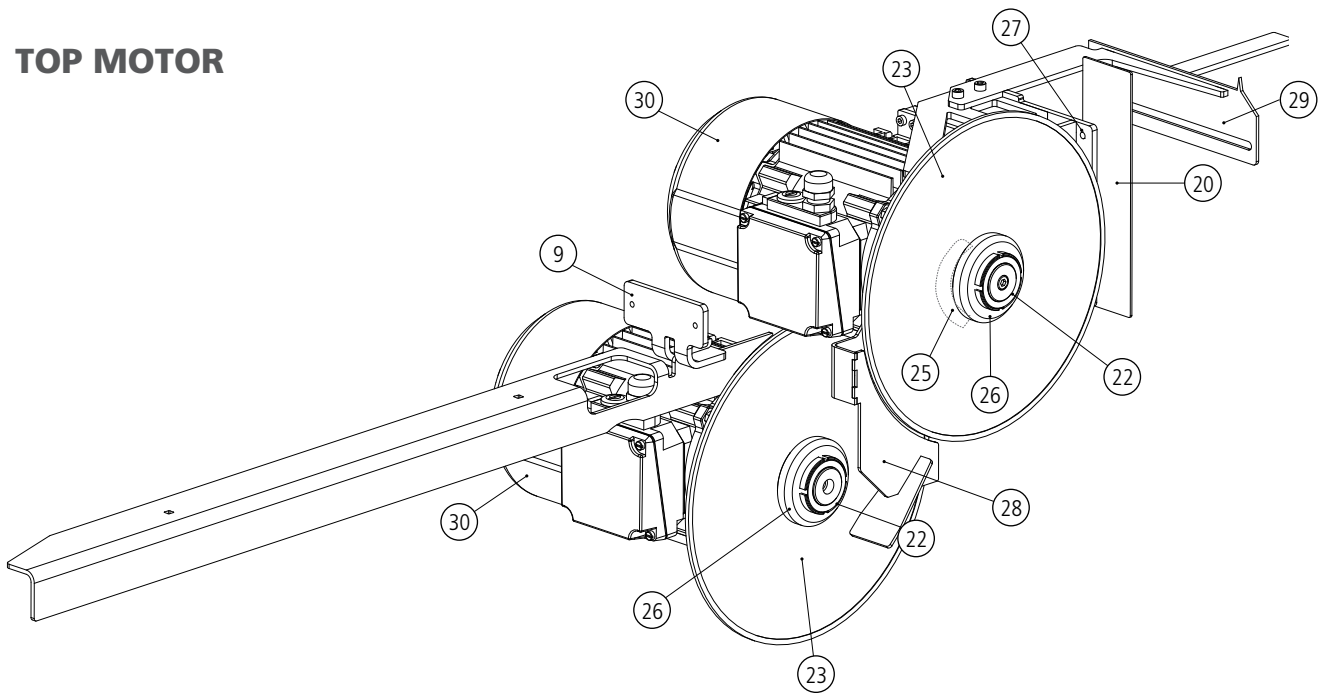

DESCRIPTION OF MACHINE

Logosol Edger 210 has twin-spindle circular saw blades for the edging of wood pieces with thicknesses of 12 to 30 mm. One workpiece at a time can be fed into the machine.

The machine is designed and built up around a solid steel rack. Each circular sawblade is fitted to a separate motor and the sawblades are positioned above and below the workpiece which is fed through the machine by a mechanical feeder unit. The top circular saw spindle is adjustable in the lateral direction. The feeder rollers are positioned on each side of the blades, so that both in-feed before the sawing process and out-feed after the sawing process takes place mechanically.

Behind the fixed circular sawblade is an extended riving knife which also acts as guiding stop. The stop can be adjusted to achieve straight working of the workpiece sides.

The machine's dangerous parts are protected by narrow slots which are formed between the edger table and special protective plates. There is a guard on the side of the machine which is pushed upwards by the workpiece if this is broader than the edger table. Safety switches are also fitted to the inspection hatch which is located closest to the circular sawblades.

The machine should be supplemented on the in-feed and out-feed side with an extension table suitable for the purpose and with an aid that ensures the workpiece is placed straight in the machine.

THE MACHINE'S MARKINGS



1. Nameplate
2. Emergency stop button
3. Start sequence

REQUIRED TOOLS

- Allen key 4 mm
- Allen key 5 mm
- Allen key 13 mm 2 pcs
- Allen key 10 mm 2 pcs
- Hook spanner for the circular sawblade (5220-001-0099)
- Wood block for locking the blade
- Straight guide rail 1m
- Sighting string or long straight board.
- Marker pen

LIFTING INSTRUCTIONS

! The machine is not to be lifted by hand.

1. The machine has a lifting eye on the top of the chassis. This faces downwards on delivery. Turn the eye upwards so that the lifting eye passes up through the chassis. The machine can then be lifted using this eye. Make sure the bolts are fully tightened after the eye has been turned.

2. The machine can be moved using a pallet jack. Place a protective layer of, for example, wood or rubber between the lift and the machine, to protect the paint.

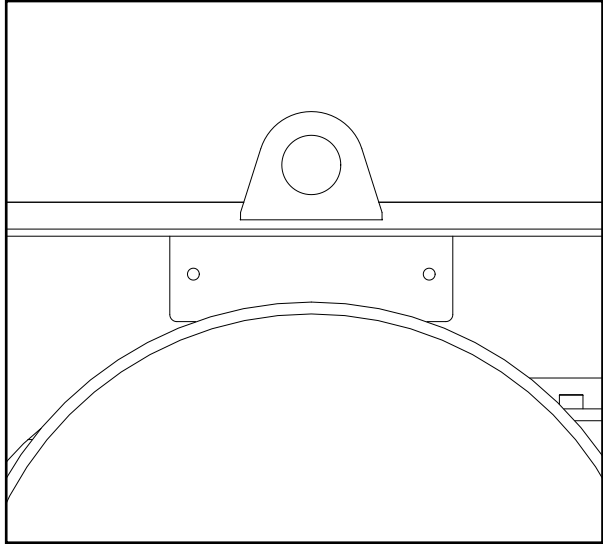

TRANSPORT OF THE BOARD EDGER

If the machine is to be transported on a trailer, then it is to be secured in place with straps that are sufficiently strong, based on road safety considerations. Secure the machine using minimum two straps that cross diagonally over the edger table. The machine can be made mobile by the chassis, without stand, being securely bolted to a trailer using secure fasteners. Make sure that the machine's control panel and controls are easily accessible from the operator station.

In-feed and out-feed tables must also be secured if the unit is to be transported with these fitted. Check rules for securing loads. The equipment can still need to be secured when driving on busy roads.

SITING

The machine's in-feed and out-feed table and protective plates (4, 5, 14, 15) are to be fitted to the machine before it is brought into use.

The plate which the control panel sits on is turned so that the panel is on the inside, to protect the control panel during transport. Release the plate and turn it so that the control panel is on the outside.

Most of the edger is rust protected and therefore can withstand being placed in cold spaces. Additional maintenance in the form of the lubrication of components that are not rust protected is however required. Refer to the 'maintenance' section under 'lubrication points'.



Risk of overturning.



The machine is to stand on a level and stable surface.



Stationary machines are to be fixed to the underlying surface using a secure fastening system.



Make sure that there is sufficient unrestricted space on the in-feed and out-feed side for the longest boards which are to be edged and that there is space for servicing and wood storage.



Risk of electric shock.



Protect the electrical cable against damage



Make sure that there is very good lighting.

There is to be good general lighting. Also set up a powerful lamp right above the machine. Make sure that there is no risk of being blinded by the light.

The board edger can be set up in the following way:

- With stand, without sawdust duct (57) and without sawdust plate (56). For use without sawdust extraction.
- With stand, sawdust duct and sawdust plate.
- Fitted without stand to an approx 50 cm high and level underlay, with sawdust plate and sawdust duct.

CONTROL PANEL

! **Lethal voltage. Do not, at any point in time, open the machine's electrical system unless you are authorised to do so.**

The machine's motors can only be started in a specific start sequence:

1. Fixed circular sawblade
2. Movable circular sawblade
3. Feeder unit

- The black spring-loaded lever starts the two circular sawblades when it is turned to the right and then to the left.
- Green rectangular button: Starting the machine.
- Red rectangular button: Stop

! The round red and raised button is the emergency stop. The emergency stop button must be pulled outwards until a click is heard, to restart the machine.

! The buttons must be easily accessible and are

! not to be blocked. Carry out the 'Pre-start check', refer to the safety instructions.



IN-FEED AND OUT-FEED TABLE

Logosol can supply ready made, 1.1 m long, in-feed and out-feed tables. Tables can be connected together to achieve the required length. (1 x table, part.no. 5220-001-0090, 1 x leg for table, part.no. 5220-001-0092)

The table has a side stop on the in-feed side which facilitates guidance and prevents the workpiece jamming in the saw opening's right side.

You can also build your own in-feed and out-feed table yourself, for example from wood. It is important that the edger table is in line or somewhat higher than the in-feed and out-feed table to

ensure that the feeder unit can draw the workpiece through the machine.

 There are extension table attachment points at the ends of the edger table.

 An in-feed table is recommended as safety is increased through the operator being prevented from standing in the rebound risk area.

SAWDUST HANDLING

Board edgers used outdoors and with a stand can be operated without sawdust extraction. Sawdust plate (56) is to then not to be fitted and the hole for the sawdust duct is to be closed.

Make sure that any sawdust which has collected under the machine is regularly removed using, for example, a spade.

Sawdust extraction is to be used when the machine is used indoors.

When a sawdust duct and chip plate are fitted to the board edger, sawdust extraction must be connected using a 100 mm hose to a sawdust extractor with a capacity of minimum 800m³/h.

The fire risk and dust emissions (releases) associated with sawdust collection must be taken into consideration.

Fire risk and dust emissions associated with sawdust handling.



Contact the local authorities for advice on the regulations which apply in your area.



Connect the exhaust hose and attach it, using hose clamps, to both the edger and the chip extractor. Use Flexi hose from Logosol (L:3m, part. no: 7000-000-1013) which has a smooth inside which improves flow.

- Hoses with steel wire mesh reinforcement are to

be earthed. (Logosol's Flexi hose does not have steel wire mesh.)

- If you want to transport the sawdust across a longer distance: Place the fan close to the edger, so that the hose is as short as possible. Then lead the sawdust away in a sheet steel pipe which has a lower air flow resistance. Contact Logosol for advice on sawdust pipes.

Position the chip extractor so that its switch is easily accessible.



Logosol has a 'Master-slave switch' which automatically controls fan activation when the edger is started or stopped!

SETTINGS

SETTING COMBINED RIVING KNIFE AND JOINTER STOP.

The riving stop is the riving knife behind the fixed blade which acts as a guide stop. The length is 910 mm.

The riving stop's front section is, in the basic setting, to be in line with the middle of the circular sawblades. The attachment point by the circular sawblade is preset on delivery.

 There is to be space in the kerf on both sides of the riving stop's tip closest to the circular sawblade. The riving stop is 4 mm thick and the circular sawblade gives a 4 to 4.2 mm kerf.

 The riving stop direction is to be set so that it is in line with the direction of the circular sawblade. For basic settings for this direction:

- Place a straight object against two of the circular sawblade's teeth and set the stop so that it is in parallel with this line.

When test running, note whether the workpiece's rear end is moved in any direction. Adjust the stops rear edge in the direction in which the rear end is moved.

INSTALLATION OF SHORT RIVING KNIFE

There is a riving knife behind the top and moving sawblade. This is to be in line with and centred on the circular sawblade. The distance between the riving knife and the sawblade is to be 5-10 mm.

The short riving knife is set on delivery. Adjustment of the riving knife's parallelity and position is carried out by carefully bending its mounting plate.

 There is to be space in the kerf on both sides of the short riving blade.

SIGHTING LINE

It is important to feed-in boards in the right direction. Place a straight board against the stop and feed through the machine towards the in-feed side. Temporarily mark the line on the in-feed side. The direction of the line may need fine adjustment after test running. Use a laser point or laser line as sighting aid.

EDGING BOARDS

When sawing logs in your sawmill, you are likely to have collected unedged boards of different widths from the logs' side cuts. Sort the boards by width into, for example, roughly two or three piles. This will reduce set-up times.

Carry out the **'Pre-start check'**. Set the required sawing width and start the machine. Keep in mind that the degree of drying should be compensated for.

Place the board on the in-feed table and aim it straight towards the machine using a laser, sighting line or an extended side stop on the in-feed side (refer to the in-feed and out-feed table).

Leave a margin of minimum a couple centimetres from the right side of the saw slot along the entire board. Pay particular attention to whether the board is crooked or has large root swelling.

The fixed circular sawblade must be engaged for the edger to saw straight. Boards with unevenness of more than 9 cm on both sides should not be edged in the board edger or edged in two work operations.

IF A WORKPIECE JAMS

Be careful when feeding in boards and watch in particular out for workpiece unevenness or root swelling on the right edge that comes into contact with the side of the machine.

Avoid feeding in visibly warped or crooked workpieces.

Soft wood and wet wood types are more difficult to feed through the machine.

If feeding stops without visible cause, lightly try and assist the workpiece through the machine in the direction of motion, whilst standing beside the workpiece.

If the workpiece is too far to the right and jams against the machine chassis: Stop the machine. Disconnect the connection cable.

Release the pressure on the pressure rollers through removing the pressure rollers' mounting plates. Draw the board out.

If the workpiece jams due to the height being too high: Dismantle the right protective plate (4), dismantle the pressure rollers' mounting plates, draw out the board.

THE ELECTRICAL SYSTEM

 Lethal voltage. Do not, at any point in time, open the machine's electrical system unless you are authorised to do so.

 Check that cables and contacts are in good condition and that the voltage, frequency and fuse are correct.

Connect the machine and check the machine's direction of operation is correct. Refer to the label on the front of the rack. The two circular sawblades are to rotate clockwise seen from the operator's station and as shown by the symbol alongside.

 The contact does not need to be opened to switch phases.

Switch the phases in the connector contact on the machine by pressing in and turning the white plate which two of the pins are located in. Use a large flat screwdriver, refer to fig.

 The machine has zero voltage switches. Automatic re-start after loss of power is prevented.

 The machine has safety switches in the top inspection panel, which are in series with the two saw motors' overheating protection.

CHECK:

 Check that the machine stops when the emergency stop button is pressed in.

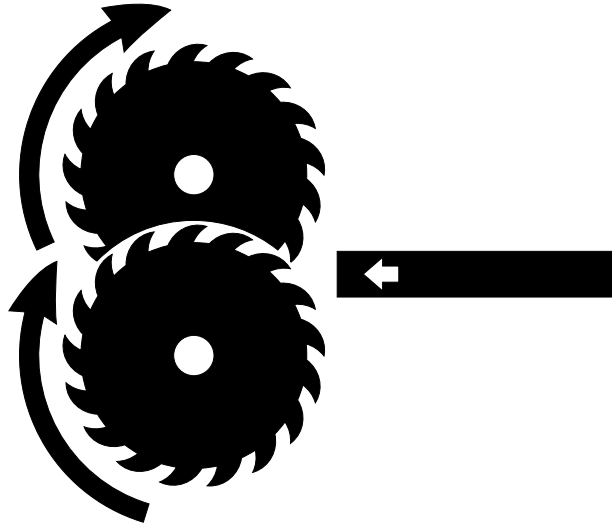

The symbol shows the direction of rotation of the circular sawblades seen from the operator's station. The white arrow shows the workpiece feed direction.

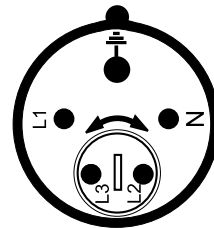

The picture shows the 3x400V connection contact function. Phases L2 and L3 can be turned around so that they change places. Press down the catch between the pins using a flat screwdriver and turn carefully around.

WIRING DIAGRAM

⚠ Lethal voltage. Incorrect connection can result in life threatening injuries.

! Note that authorisation is required to open or carry out work on the electrical equipment.

! Make sure that the power has been fully shut off before opening the system.

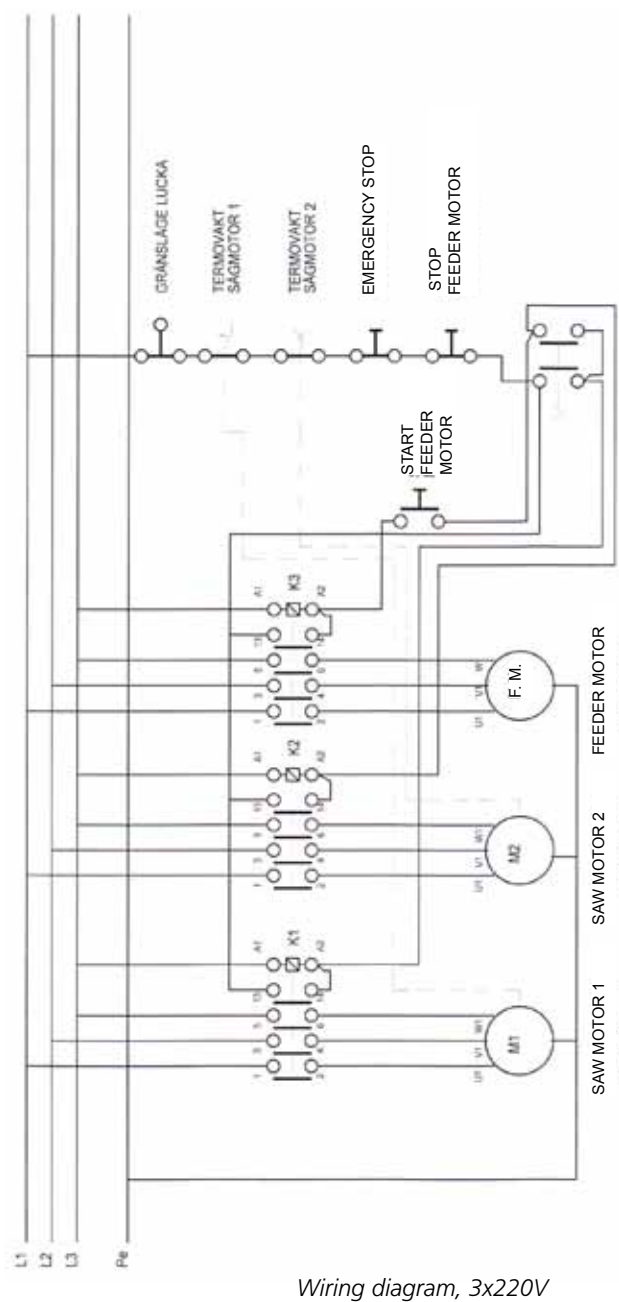
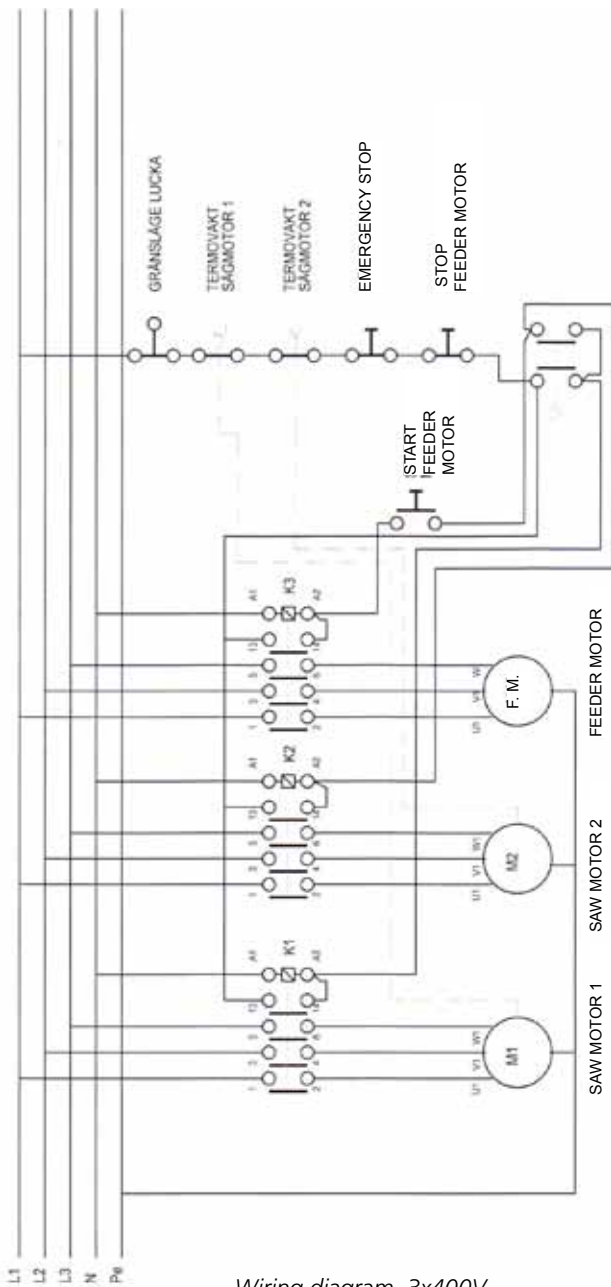

EFFECT OF EXTERNAL ENVIRONMENT



Special attention should be paid to external environment factors.



Risk of water accumulating in the machine's electrical system, which can lead to personal injury and damage to the machine.

The motors can be damaged if the machine is stored or is used at temperatures below zero degrees C or if it is stored in damp unheated environments. The water can condense and collect in the motors (this applies to most sealed motors). There is a drain plug on each motor which can be removed to check that the motor is dry inside.

Water can also collect in the control panel where temperature variations are significant. When the machine has stood in an environment where there is a risk of condensation, check that water has not collected before the machine is used.

If the machine is not used for a longer period of time:

- All power is to be disconnected and the machine is to be thoroughly cleaned.
- Repair any damage to paint; wash with alcohol, scrape off rust and fill the damaged area with touch-up paint from Logosol or with automotive paint. This is to prevent creeping rust which can increase the damage.
- Coat table surfaces with a universal lubricant or Silbergleit. Spray the feeder rollers, the circular sawblades and the circular sawblade mountings with universal lubricant. The machine should ideally be stored in a heated space. If this is not possible, make sure that the machine is carefully covered and not in direct contact with the ground.



The lifetime of the machine's surface layer can be significantly reduced if the machine is installed in an aggressive environment, such as

near the sea, close to a motorway or if corrosive wood types are processed in the machine. Clean and lubricate particularly carefully where the machine is in an aggressive environment.

REPLACING CIRCULAR SAWBLADES



Risk of serious injuries.



Only use circular sawblades supplied by Logosol. The circular sawblade which is to be used has a part number: 5220-001-0058



Warning! Bluntness increases the risk of accidents.



Risk of unintentional start and serious injuries.



Before opening the machine, make sure that the electrical power is shut off and that the circular sawblades are not rotating. Use protective gloves.

Dismantle the inspection hatch which is on the top of the machine rack. Always remove the top circular sawblade first and then the bottom.

Removing the sawblade: Undo the Allen head bolt which locks the nut onto the spindle. (4 mm Allen key). There is a small radially placed screw which fastens a part of the nut's thread to the spindle shaft thread.

Lock the rotation of the sawblade with a piece of wood that is suitable for the purpose.

Loosen the spindle nut using the special key (X). Both the spindle nuts are right-hand threaded, i.e. normal thread direction.

Check that the sawblade is correctly positioned and that the carrier pin is inserted the circular sawblade hole.

Fit the spindle nut and tighten it towards the sawblade by hand. Lock the circular sawblade using the wood piece and tighten it using the special key (ca XX Nm).

Tighten the radial thread lock using the Allen key.

After replacing a circular sawblade



Check that the circular sawblade is fitted in the right direction. Both the circular sawblades are to be fitted in the same direction, and saw in the opposite direction to the feed direction. Refer to illustration on the nameplate.



Check that the spindle can rotate freely.



Check that no tools have been left in the machine.

TECHNICAL DATA

LOGOSOL C210	
PROCESSING MEASUREMENT	
Max material width	Unl. mm
Max splitting width	215mm
Max workpiece height	30 mm
CIRCULAR SAWBLADES	
Diameter	300 mm
Rotational speed	2800 rpm. Circular sawblade stop time, approx: 8 sec. Only circular sawblades supplied by Logosol are to be used.
SAWDUST HANDLING	
Sawdust duct diameter	100 mm
Required chip extractor capacity	min. 700 m ² /h
POWER SUPPLY	
Feed rate	ca: 10 m/min
Number of rollers	2
DIMENSIONS	
Length	2140 mm
Width	800 mm
Height	754 mm
Rack height	480 mm
Weight	ca 150 kg
ELECTRICAL SYSTEM	
Power supply	CCA16 A, 400 V 50 Hz three phase (Alt: 25A 230V 50 Hz three phase, when the machine is fitted with eldon NO 5220-001-0066.)
Protection rating	IP54
Rated power	4.6 kW.
Main breaker	The contact for power supply is disconnected.
NOISE LEVELS	
Sound pressure level	100.4 dB(A)
Noise effect value	107.6 dB(A)
ACCESSORIES	Rack Height 500 mm, sawdust ejector, in-feed and out-feed table, chip extractor, flexi hose, moulding knife, etc. Refer to Logosol's product catalogue which can be ordered free of charge.

Declaration of conformity

Logosol AB
Fiskaregatan 2
S-871 31 Härnösand, Sweden
Tel. +46 611 18285

hereby declares that the Logosol C210 Board Edger,
part. no. 5220-000-1000, 5220-000-2000
has been manufactured in conformity with:

the Machinery Directive 2006/42/EC, the EMC Direc-
tive 2004/108/EC and the LVD Directive 2006/95/EC,

and in accordance with the following harmonized
standards: EN ISO 12100:2010, EN 60204-1:2006,
EN 61000-6-1, -3

Notified organ:
SMP Svensk Maskinprovning AB 0404, Uppsala,
Sweden has issued:

Type examination certificate: 0404/12/2353

Mattias Byström, product development manager, is
responsible for the technical files.

Härnösand 05/10/2012

Malte Frisk, CEO



**LOGOSOL SWEDEN**

Fiskaregatan 2, S-871 33 Härnösand, Sweden
Phone +46 (0) 611-182 85 | Fax +46 (0) 611-182 89
info@logosol.se | www.logosol.se