

LOGOSOL *Planer/Moulder PH260*

The Logosol PH260 4-Head Planer/Moulder is a revolution in four sided planers.

Tried and proven in Europe for over nine years, Logosol now presents with full confidence the most versatile planer on the market today. Logosol engineers recognized the need for a smaller, lighter planer; one with full capabilities and ready for hard industrial work. This planer does not take up a lot of space in your workshop, and can even be mounted on wheels. The PH260 does the job of commercial planers many times its size, weight, and price! Whether you are a commercial business with big planers already in use and need the added capability and versatility of the new PH260, or an independent sawmill operation that wants to increase the value of the lumber you produce and provide new services to your customers, the Logosol PH260 is the planer for you!



The machine above is equipped with in/out feeding tables (optional).



Logosol, a world leader in wood processing equipment, makes "one pass" production possible with the PH 260 Planer/ Moulder. This unique moulder planes and moulds four sides in one pass.



Precision Construction Insures Quality Production

One difference between the PH 260 and other 4-sided planers is that the top and bottom cutting head axles have bearings on both ends. This provides higher stability.

Small Footprint - High Capacity

This planer/moulder takes up only 43" X 35". This planer is easily moved on a pallet or wheels to where you need it in your shop, or mount it permanently in a minimum amount of space for continuous high capacity production.

Quick and Easy Settings

Don't turn away those small special moulding orders anymore! 10-20 minutes is all you need to allow for changing to new profiles on the PH 260 Planer/Moulder. This simple and quick setup system makes changing moulding knives a snap!

Solid Feeding Design

5 feeders provide a good grip on rough lumber and nylon inlays in the table guarantee the secure feeding, even if the material has a lot of sap. The out feeder is made of rubber to prevent marks on the finished molding.

Big depth

The cutters can handle a large moulding depth up to 3/8". This gives the PH 260 the capacity to cut deep and beautiful mouldings. The PH 260 has also a fantastic capacity to dimension lumber, the upper cutter can cut 5/16" in one pass.

Mouldings

The Logosol PH 260 can handle everything from 4" loghome timbers to picture frame mouldings. You can choose from a big variety of standard moulding knives, or you can custom design your own moulding knives. Both the standard and the special moulding knives have very reasonable prices.

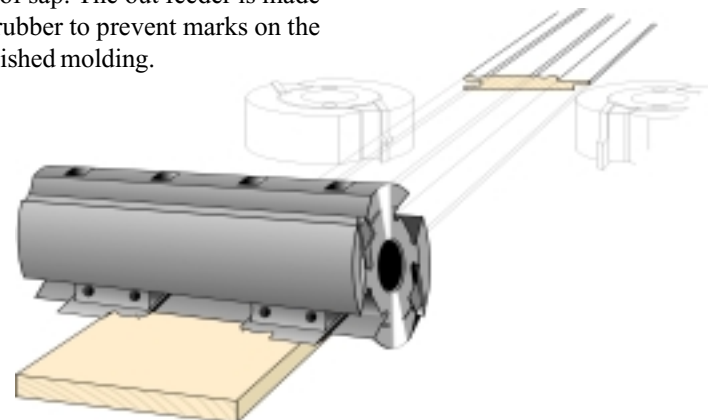

Technical Specs - PH 260

4-sided planing/moulding

Width: 0-10" (0 - 260 mm)
Depth: 9/16"-4" (13 - 100 mm)

2-sided planing/moulding

Planing: width 12" (300 mm)
Depth: 3/8"-9" (10 - 230 mm)

Planing

Planing width: 13" (330 mm)
Depth: 3/8-9" (10 - 230 mm)

Upper Cutter Head

Diameter: 2 7/8" (72 mm)
Width: 16" (410 mm)
Effect: 3 KW (4hp)
7000 rpm
Planer depth: max. 5/16" (8 mm)
Moulding depth: max. 3/8" (10 mm)

Bottom cutter head

Diameter: 2 7/8" (72mm)
Width: 12" (300 mm)
Effect: 3 KW (4hp)
7000 rpm
Planing depth: 0-3/32" (0-4 mm)

Side Spindles

Spindle axle: diameter 30 mm
Cutting height: max. 4 "(100 mm)
Diameter: max. 5 1/2" (140 mm)
Effect: 3 KW (4hp)
7000 rpm
Cutting depth: max. (1 3/32")

Standard Cutter Heads

Type: TB90
Diameter: body 3 1/2" (90mm)
Height: body 1 9/16" (40mm)
Planer knives: HSS
Knives: width 2" (50 mm)

Feeding

Effect: 0,37 KW (0.5hp)
Feeding speed: 11-52 ft/min

Electric System

Moisture Class: IP54
Total effect: 12.4 KW (16.5hp)
Supply: 3-phase, 220 V, 30A
Supply: 1-phase, 220 V, 50 A

Size

Length and width: 43"x35"
(1100 x 900 mm)
Height: 38" (970 mm)
Weight: 370 kg (820 lbs.)

Accessories

Rubber Feeders
Rubber Casters
In and Out Feeding Tables
Chip extractor 3-phase
Chip extractor 1-phase
Rotary Phase Converter

www.logosol.com